

Simulation of Cycloconverter Fed Split Phase Induction Motor

Md Umar Faruk, Manoj Kumar Mishra, Ipsita Pahi, Poonam Tripathy

Department of Electrical and Electronics Engineering, NM Institute of Engineering and Technology, Bhubaneswar, Odisha

Department of Electrical and Electronics Engineering, Raajdhani Engineering College, Bhubaneswar, Odisha

Department of Electrical and Electronics Engineering, Aryan Institute of Engineering and Technology Bhubaneswar, Odisha

Department of Electrical and Electronics Engineering, Capital Engineering College, Bhubaneswar, Odisha

ABSTRACT: Single-phase induction motors are widely used in many applications. Improvements in its performance mean a great saving in electrical energy consumption. A cycloconverter fed variable frequency motor is a typical example of such improvement. In this regard, the paper presents an analysis of the performance and speed control of the split phase induction motor when it is fed with cycloconverter. Dynamic models and analysis of the motor behavior during transient and steady state phases are presented. A speed controller based on cycloconverter is proposed. The controlled motor exhibited better performance at starting state. A cycloconverter is a device that converts AC, power at one frequency into AC power of an adjustable but lower frequency without any direct current, or DC, stage in between. It can also be considered as a static frequency changer and typically contains silicon-controlled rectifiers.

KEYWORDS: Cycloconverter, Split phase Induction Motor, MATLAB.

I. INTRODUCTION

Analysis of induction motors controlled with cycloconverter has been investigated extensively [1]. The single phase induction motor in its simplest form is structurally the same as a poly phase induction motor having a squirrel cage rotor, the only difference is that the split phase induction motor has single winding on the stator. The split phase induction motor is the most commonly used motor in the utility network [3&4]. which produces mmf stationary in space but alternating in time, a polyphase stator winding carrying balanced currents produces mmf rotating in space around the air gap and constant in time with respect to an observer moving with the mmf [5&6]. Split phase induction motors are usually built with small power, they are widely used in domestic and commercial applications. This paper shown a speed control scheme for a split phase induction motor fed with cycloconverter. Cycloconverters are used in very large variable frequency drives with ratings from few megawatts up to many tens of megawatts. The following sections will describe the operation principles of the cycloconverter starting from the simplest one, single-phase to single-phase (1f-1f) cycloconverter. A single-phase input cycloconverter is shown in Fig.1, single-phase input to single-phase output cycloconverter is shown in Fig.4, the simplest cycloconverter circuit. The secondary transformer of the power supply for the cycloconverter consists of two separate windings, which can provide 180° displaced input voltages to each of the two thyristor half bridges. As there are two controlled timing pulses for each thyristor half bridge, this topology is referred as a 2-pulse (or 4-pulse in circulating current mode) cycloconverter.

II. CYCLOCONVERTER

The cycloconverter is connected as shown in Fig.6[2], which is operating without circulating current; the non-conducting thyristors should always be kept off otherwise the input power supply could be shorted via the positive and negative thyristor half bridges. When the load current is positive, the output voltage is only controlled by phase control of thyristors T1 and T3 at the same time, the other two negative thyristors T2 and T4 are kept off and vice versa when the load current is negative. When the load current changes its direction at the same time ensuring that the two thyristor half bridges do not conduct at the same time. If the cycloconverter is operating in circulating current mode, both thyristor half bridges are continuously conducting, eliminating the output voltage distortion during load current zero crossing but additional coupled reactors are required between the two thyristor half bridges to limit the circulating current. Although the output voltage of the cycloconverter can be improved in circulating current mode, the circulating current reactor tends to be bulky and more expensive and the presence of the circulating current will degrade the input power factor.

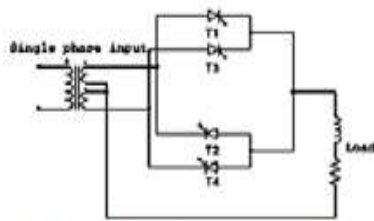

Fig.1: Single-phase input cycloconverter

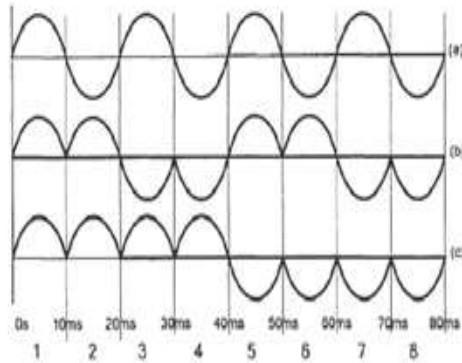

Fig.3: (a) Input 50Hz (b) Output 25Hz
(c) Output 121/2Hz

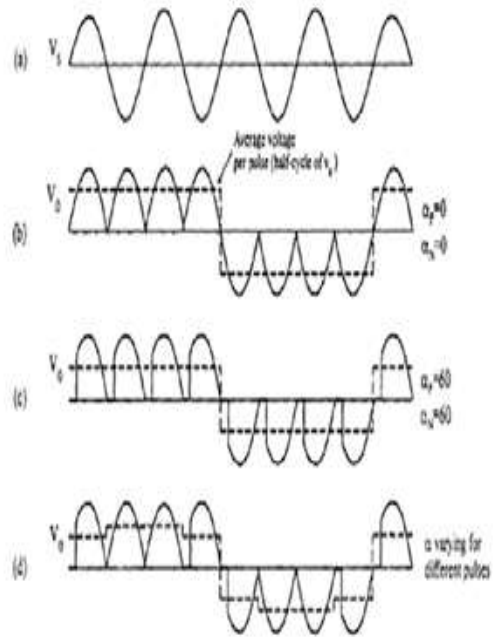

Fig. 2: Single Phase Cycloconverter Outputs a) Input voltage
b) Output voltage for zero firing angle c) Output voltage for firing angle of 60 degrees d) Output voltage with varying firing angle

Fig.2-d shows the firing angle of the thyristors changing over the cycle of the output. This dynamic process produces an output waveform that more closely resembles a sinusoid than the non-dynamic process in Fig.2-b [7]. However, even in this last improved waveform the output is far from sinusoidal.

III. MODELING OF SPLIT PHASE INDUCTIONMOTOR

Split phase induction motors are usually constructed with two windings on the stator side and squirrel cage winding in the rotor side. The auxiliary winding is used to produce a rotating field to start the motor. The axis of the auxiliary winding is placed 90 electrical ahead of the main winding as shown in Fig.4. The lively simulation of the motor is presented in the stationary d-q frame to facilitate the application of the inverter and, later on, the feedback regulators. Since the axis of the main and auxiliary windings are already orthogonal, the stationary d-q axes are chosen aligned with the orthogonal axes of the physical windings. The squirrel cage rotor is represented by equivalent two coils transformed to the stationary d-q axis as shown in Fig.4.

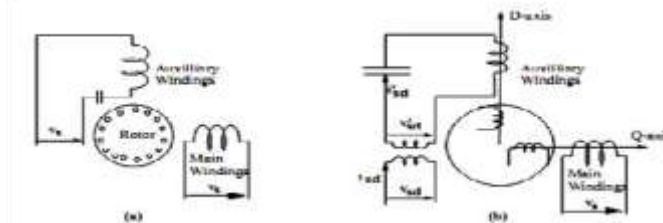

Fig.4: d-q Transformation of the Split Phase Induction Motor

Since the two stator windings; namely the main and auxiliary coils, have different number of turns, they will yield different mutual reactances. Therefore, a transformation is made to transfer the auxiliary winding to an equivalent winding with the same number of turns as that of the main coil. The new variables referred to the equivalent coil are given as follows:

$$v'_{sd} = V_{sd} \cdot (N_{sq} / N_{sd})$$

$$r'_{sd} = r_{sd} \cdot (N_{sq} / N_{sd})^2$$

$$X'_{sd} = X_{sd} \cdot (N_{sq} / N_{sd})^2$$

$$X'_c = X_c \cdot (N_{sq} / N_{sd})^2$$

The voltage equation of the motor can be written in the d-q stationary frame as follows [4]:

$$v'_{sd} = r'_{sd} i'_{sd} + \frac{1}{\omega_o} \dot{\psi}_{sd} + v'_c$$

$$v_{sq} = r_{sq} i_{sq} + \frac{1}{\omega_o} \dot{\psi}_{sq}$$

$$0 = r_r i_{rd} + \frac{1}{\omega_o} \dot{\psi}_{rd} + \frac{\omega_r}{\omega_o} \psi_{rq}$$

$$0 = r_r i_{rq} + \frac{1}{\omega_o} \dot{\psi}_{rq} - \frac{\omega_r}{\omega_o} \psi_{rd}$$

$$\dot{v}'_c = \omega_o X_c i'_{sd}$$

[1],[2]

The equations of motion are given by:

$$T_e = \frac{P}{2\omega_o} (\psi_{sd} i_{sq} - \psi_{sq} i'_{sd})$$

$$\dot{\omega}_m = \frac{P}{2J} (T_e - T_L - T_{damp})$$

Where:

$\psi_{sd}, \psi_{sq}, \psi_{rd}, \psi_{rq}$ are the d-q- stator and rotor flux linkage, respectively.

X_{sd} is the d-axis stator leakage reactanc. r_r is the rotor resistance,

r_{sd}, r_{sq} are the rotor resistance,

ω_o is the base speed, 314 rad/sec,

ω_r is the rotor speed, electric rad/sec, T_e is the developed torque,

T_L is the loadtorque,

T_{damp} is the damping torque, P is the number ofpoles.

IV. SIMULATION RESULT

Simulink model is shown in Fig. (5, 6). The objective of this paper is to analyse the speed of induction motor performance . The stator of a split phase induction motor has two windings, the main winding and auxiliary winding. Since, the d-q axis model of an induction motor is only valid for sinusoidal input voltage, the cycloconverter voltage output must be decomposed into its fundamental. Fig. (7-8) shows output phase voltages and currents for input frequency is 2 times the output frequency of the 1-phase cycloconverter.

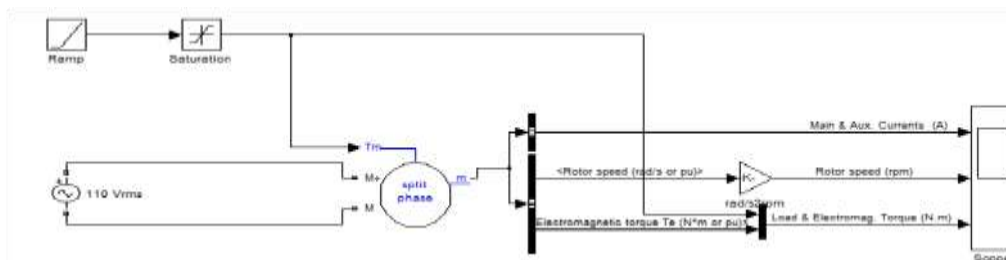

Fig.5: Split Phase Induction Motor

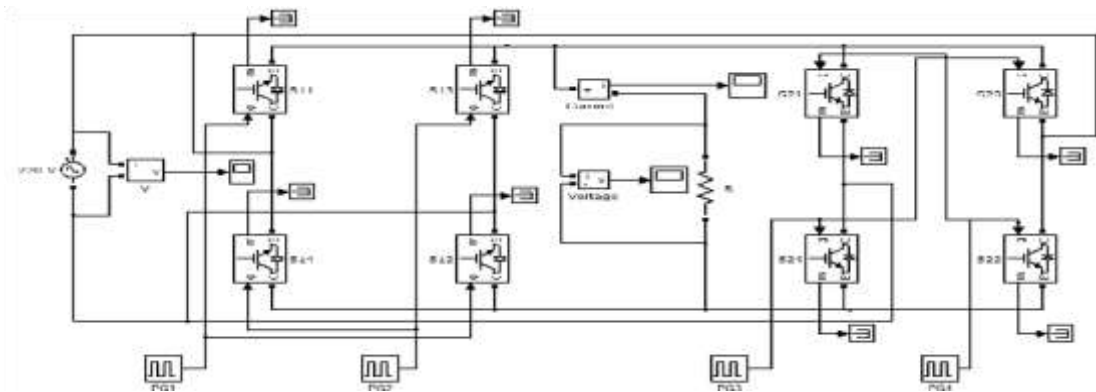

Fig.6: 1- phase to 1- phase cycloconverter

Fig.(10-11) shows output phase voltages and currents for input frequency is 3 times the output frequency of the 1-phase cycloconverter. From control standpoint, the proposed cycloconverter simulation result shown in Figure. In order to get a better understanding of the control system and to verify the control techniques described by researcher in previous research paper [2], a Simulink model was developed as shown in Figure 6. The simulation starts with the 50 Hz reference sine wave is generated.

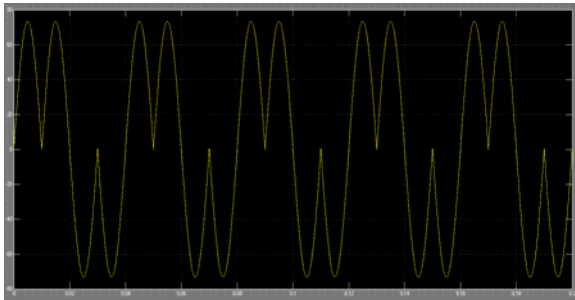

Fig.7: Voltage Waveform shows the input frequency is 2 times the output frequency

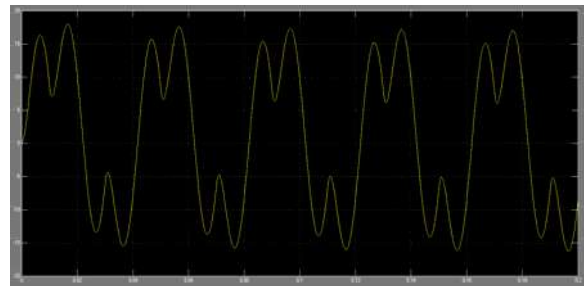

Fig.8: Current Waveform shows the input frequency is 2 times the output frequency.

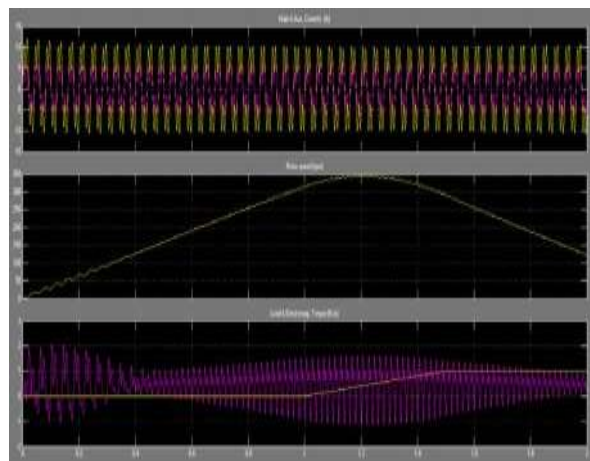
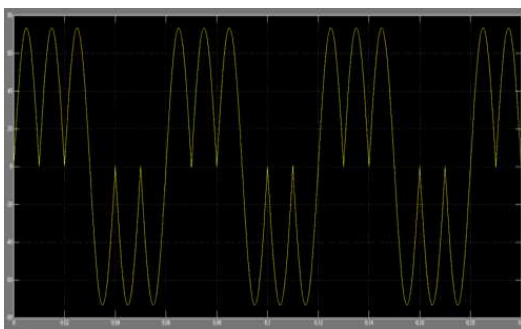

Fig.9: Waveform shows the input frequency is 2 times the output frequency (a) Main & Aux. Current (b) Rotor Speed (c) Load & Electro. Torque

Fig.10: Voltage Waveform shows the input frequency is 3 times the output frequency.

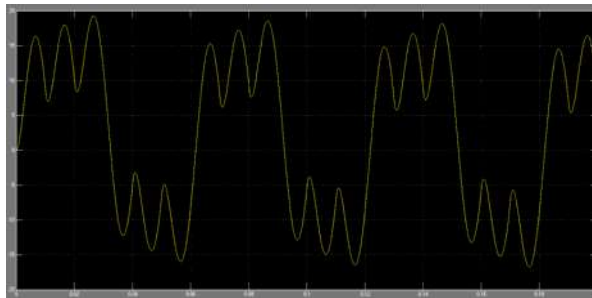

Fig.11: Current Waveform shows the input frequency is 3 times the output frequency.

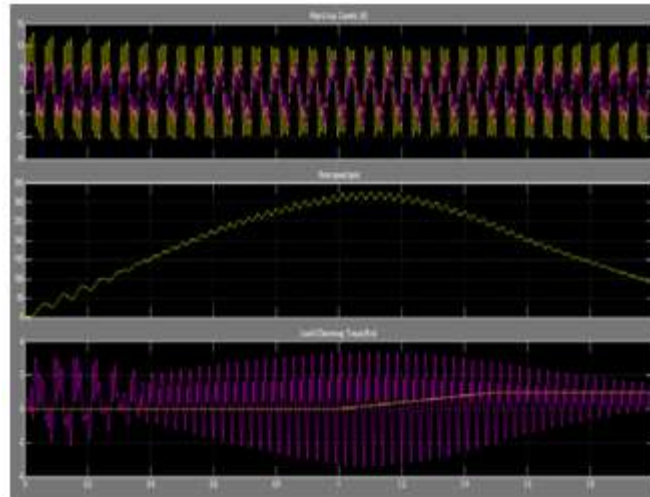

Fig.12: Waveform shows the input frequency is 3 times the output frequency (a) Main & Aux. Current (b) Rotor Speed (c) Load & Electro. Torque

From the above discussion and from the waveform shown in fig following point may be noted. The average output voltage waveform is far from sinusoidal since the firing angle is held constant. The current waveform not repeated after every cycle Fig.8. Some circulating current is allowed to flow from the positive converter to the negative converter. In this case a circulating current limit in reactor is connected between the positive and negative converter. In order to obtain reasonably good sinusoidal or square output voltage waveform using line commutated two quadrant converter and eliminating the possibility of short circuit of the supply voltage, the output frequency is limited to a value much lower than supply frequency.

V. CONCLUSIONS

The cycloconverter circuits are designed and simulated and desired results are obtained. Single phase cycloconverter used for Single phase motor to generate supply torque characteristics that matches with demand torque characteristics of particular machine by the use of designing cycloconverter different desired frequency are obtained to equalize the torque demand of machine. This different frequency of cycloconverter is also useful to replace flywheel from the operating machine which reduces the cause of torsional vibration and fatigue damage of machine. The paper proposed a feedback control scheme of cycloconverter fed split phase induction motor. Furthermore, it provides means for limiting the slip and consequently the motor current. This means a reduction in the cycloconverter rating and better efficiency. This contribution will report on the results obtained using matlab for single phase cycloconverter coupled to an induction motor.

REFERENCES

- [1] Paul C. Krause, Oleg Wasynczuk, Scott D. Sudhoff, Analysis of Electric Machinery and Drive Systems, 2nd ed., ISBN: 978-0-471-14326-0, Wiley-IEEE Press, 2002.
- [2] Sandeep Pande, Harshit Dalvi, "Simulation of Cycloconverter Based Three Phase Induction Motor" International Journal of Advances in Engineering & Technology (IJAET), 2011. ISSN: 2231-1963 July 2011.
- [3] Maamoun, A., "Development of cycloconverters," Canadian Conference on Electrical and Computer

- Engineering, 2003. IEEE CCECE 2003. Vol.1, 4-7 May 2003, pp.521 –524
- [4] M. Abdel-Halim, H. G. Hamed, and K. M. Hassaneen, “Modeling and Simulation of VSI-FED Induction Motors”, Middle East Power Systems Conference (MEPCON’2000),pp.80-84.
- [5] D.M. Manjure and E. Makram ”Effect of converter Drive on Power Systems”,Middle East Power Systems Conference (MEPCON’2000), March 28-30, 2000, pp.28-32.
- [6] Chen-Mun Ong, Simulation of Electric Machinery, ISBN: 0-13-723785-5, Prentice Hall, NJ 07458,1998.
- [7] B Ozpineci and L. Tolbert,“Cycloconverters.”
- [8] SongchunZhang,FenglinWu,ShminShen,ShuchunYang,“ADigitalControllerBased Cycloconverter Fed Drive”, 1997 IEEE Transaction, pp.637-641
- [9] Z. Wang and Y. Liu, “Modeling and Simulation of a Cycloconverter Drive System for Harmonic studies”, IEEE Transactions on Modern Electronics, vol. 47, no. 3, June 2000, pp.533-541.
- [10] M. Adli, R. Mecke, F.Palis, “ A New Control Strategic of Quasi- Cycloconverter Fed Induction Motor drive” in 1993, The European Power Electronics Association, pp.82-87.
- [11]